



WEATHERPROOF HORN LOUDSPEAKER

PH10/T

PH10/T is a compact, weatherproof horn loudspeaker, especially for a high sound reinforcement designed. It is made of a UV-resistant, reinforced ABS plastic and features an epoxy-coated stainless steel U-bracket (Stainless).

This pressure chamber loudspeaker is designed by the high performance combined with a high sound pressure especially for the reproduction of voice announcements or signal warnings.

PH10/T is resistant to saline air, most non-corrosive substances and many chemicals. Therefore it can be used also in marine or industrial applications and is ideal for indoor and outdoor use.



● Electrical	
Rated power, Watts	10
Tappings 100 volt line, Watts	10/5/2.5/1.25
Transformer Impedance, Ohms 100V	1k/2k/4k/8k
Tappings 70.7 volt line, Watts	5/2.5/1.25/0.625
Driver impedance, Ohms	20
Effective Frequency Range, Hz (BSEN60268-5)	400-8.000
S.P.L. @ 1m, 1 watt, dB, Test Signal Bandwidth 100Hz-10kHz	97
S.P.L. @ Full power Octave Bandwidth, dB	107
Acoustic Power (dB-PWL@1 watt) 1k/2kHz, dB	95/97
Dispersion at 1k/2k Hz, Degrees	180/110
Directivity Axial Q factor, 1k/2kHz	2.8/6.6
● Environmental	
IP Rating	56
Min/Max amb temp	-50°C to 70°C
Relative Humidity	n/a
● Mechanical	
Dimensions, front & depth, mm	Ø138x200
Net weight, kg	1.30
Colour/Finish	Grey RAL7035
Material	ABS plastic housing with UV inhibitors
Mounting	Stainless Steel U Bracket



ATEIS Europe B.V.
 Celsiusstraat 1, 2652 XN Lansingerland, Netherlands
 Phone +31 (0)10 208 86 90, www.ateis-europe.com, info@ateis-europe.com



INSTALLATION GUIDE

PH10/T

Side view
(unit: mm)

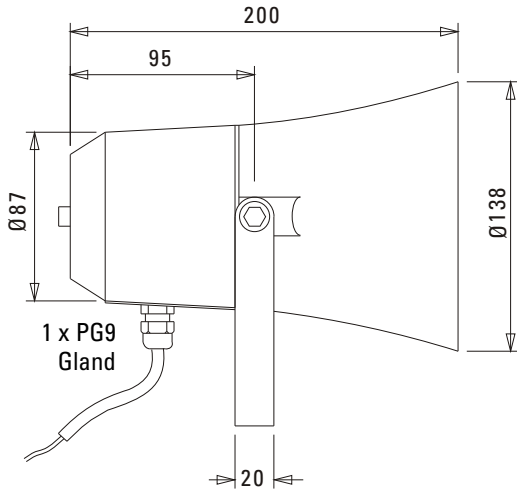

Front view
(unit: mm)

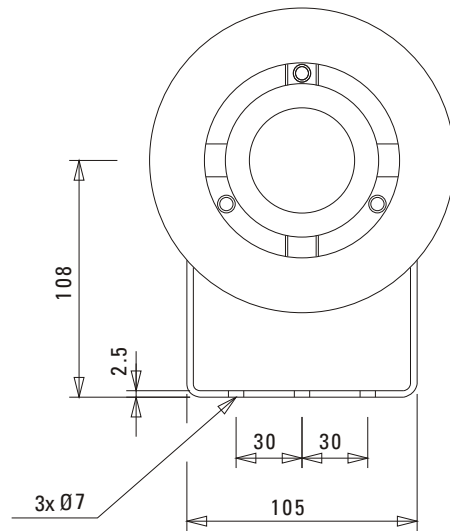

- 1) Remove the back lid of unit and connect input cable to the ceramic terminal block through the cable gland provided.
- 2) On removing the back lid of the horn you will observe a 5 way plastic terminal block that is connected to the 100 volt line transformer, fit the input cable. To select the wattage tapping required look at the top of the transformer, you will find a selection of taps from 10 watts down to 1.25 watts. To change the tapping move the female connector (white) located on the transformer to the appropriate male spade terminal. The white lead also contains a thermal fuse for circuit protection in the advent of a fire.
- 3) On selecting the tapping required and wiring the same, secure the cable gland tight into the back lid of the chamber.

- 4) Around the inner section of the chamber where the back lid was removed a rubber gasket is located; please make sure that it is in place when re-fitting the back lid to avoid water penetration. There is a fibreglass sleeve covering the central mounting bolt, it is important that this cover is used as it protects the transformer.
- 5) Drill the mounting location holes for the unit in line with the "U" bracket (2 holes 60 mm apart) in the surface where the loudspeaker is to be located. It is not necessary to use the central mounting hole in the bracket unless the loudspeaker is located on a pole mount clamp.
- 6) Mount the speaker in the required location specified by an acoustic engineer.
- 7) Before putting 100 volt line through the unit it is advisable to check the impedance of the circuit.

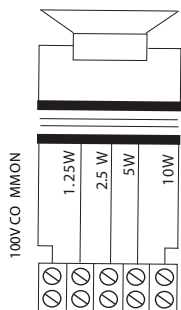

Circuit Diagram

Frequency response

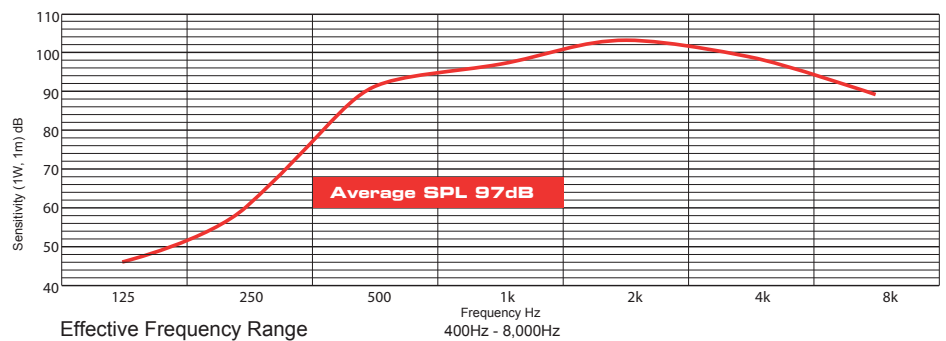

Disclaimer: We reserve the right of changes and errors.



ATEIS Europe B.V.
Celsiusstraat 1, 2652 XN Lansingerland, Netherlands
Phone +31 (0)10 208 86 90, www.ateis-europe.com, info@ateis-europe.com

